

STATE OF WASHINGTON
ENERGY FACILITY SITE EVALUATION COUNCIL (EFSEC)



TITLE V BASIS STATEMENT FOR
AIR OPERATING PERMIT – EFSEC/06-01-AOP Rev. 3

Issued To

PACIFICORP

For The

CHEHALIS GENERATION FACILITY

DRAFT: **Date XXXX**

PERMIT #:	EFSEC/06-01-AOP Rev. 3
PREPARED FOR:	Chehalis Generation Facility 1813 Bishop Road Chehalis, WA 98532
PLANT SITE:	Chehalis Generation Facility 1813 Bishop Road Chehalis, WA 98532
PERMIT ENGINEER:	Clint H. Lamoreaux – SWCAA Air Quality Engineer
REVIEWED BY:	Kyle Overton – EFSEC Energy Facility Site Specialist

ENERGY FACILITY SITE EVALUATION COUNCIL
1300 South Evergreen Park Drive SW - PO Box 43172
Olympia, WA 98504-3172
Telephone: (360) 664-1345

TABLE OF CONTENTS

I. General Information and Certification..... 1

II. Emissions Unit Descriptions..... 3

III. Explanation of Insignificant Emissions Unit Determinations 7

IV. Explanation of Selected Permit Provisions and General Terms and Conditions.....8

V. Explanation of Operating Terms and Conditions 8

VI. Explanation of Monitoring and Recordkeeping Terms and Conditions 14

VII. Explanation of Reporting Terms and Conditions 18

VIII. Explanation of Future Requirements 20

IX. Explanation of Obsolete Requirements 21

X. Explanation of Appendices (optional) 23

XI. Facility History..... 23

Appendix A: Plant Drawings

I. GENERAL INFORMATION AND CERTIFICATION

Company Name PacifiCorp

Facility Name..... Chehalis Generation Facility

Facility Address..... 1813 Bishop Road
Chehalis, WA 98532

Mailing Address 1813 Bishop Road
Chehalis, WA 98532

Parent Company/Address PacifiCorp
1407 West North Temple
Salt Lake City, UT 84116

Standard Industrial Classification 4911

North American Industrial Classification System 221112

Aerometric Information Retrieval System Number 53041-00005

Unified Business Identification 409-000-070

Responsible Official Mark A. Miller – Gas Plant Manager

Permit Engineer Clinton H. Lamoreaux – P.E.

Reviewed by Ami Kidder – EFSEC manager
Kathleen Drew – EFSEC Chair

Basis for Title V Applicability

The Chehalis Generation Facility has the potential to emit more than 100 tons per year of sulfur dioxide, nitrogen oxides, particulate matter less than 10 micrometers, and carbon monoxide, all of which are criteria air pollutants listed under the Federal Clean Air Act. A facility with the potential to emit at or above these thresholds is subject to the Title V Air Operating Permit Program. In addition, this facility is required to obtain a Title V Air Operating Permit because it is an affected source under Title IV (Acid Deposition Control) of the federal Clean Air Act.

Facilitywide Potential To Emit Summary

Pollutant	Emissions (tons per year)
Nitrogen oxides	242
Carbon monoxide	487
Volatile organic compounds	59
Sulfur dioxide	170
Particulate Matter	225
PM ₁₀	225
PM _{2.5}	225
NH ₃	226
Combined HAPs	2.0
Individual HAP	2.0 (formaldehyde)
CO ₂ equivalent	1,926,911

Current Permitting Action:

This Title V Air Operating Permit is being issued in response to a Title V renewal application submitted by PacifiCorp Energy in accordance with the deadline contained in Air Operating Permit EFSEC/06-01-AOP Rev. 2.

AOP EFSEC/06-01-AOP Rev. 3 (Renewal)

- | | |
|--|-------------------|
| 1. Permit Application Due: | June 29, 2021 |
| 2. Permit Application Submitted: | December 23, 2020 |
| 3. Permit Application Deemed Complete: | January 28, 2021 |
| 4. Permit Application Sent to EPA: | XXXX |
| 5. Draft Permit Issued: | XXXX |
| 6. Proposed Permit Issued: | XXXX |
| 7. Final Permit Issued: | XXXX |
| 8. Renewal Permit Application Due: | XXXX |
| 9. Permit Expiration: | XXXX |

Attainment Area:

The Chehalis Generation Facility is located in an area that is in attainment status for all criteria pollutants.

Facility Description:

The Chehalis Generation Facility is an air-cooled natural gas-fired combined cycle power plant. The facility includes two combustion turbines and one steam turbine. Exhaust gas from the combustion turbines is routed through heat recovery steam generators (HRSGs) which provide steam to the steam turbine. The combustion turbines and the steam turbine are each coupled to an electric generator. Electrical energy provided by the three generators is supplied to the electric power grid.

The Chehalis Generation Facility began commercial operation (for the purposes of Title IV) in June 2003. The facility has a nameplate capacity of 593.3 MW, an actual net summer capacity of 477 MW, and a net winter capacity of 506 MW. The Site Certification Agreement nominal generating capacity of 520 MW is an accurate representation of the capacity under average annual

conditions. An air-cooled condenser system is used in lieu of a wet cooling tower system to minimize water consumption. A 16.9 MMBtu/hr Auxiliary Boiler was commissioned in 2010 to provide steam to the facility to reduce the duration of startup events. No duct burners, emergency generators, or emergency fire pumps have been installed at this facility.

II. EMISSIONS UNIT DESCRIPTIONS

EU #	Generating Equipment	Emission Control
EU-1	Combustion Turbine #1	Oxidation catalyst and selective catalytic reduction system
EU-2	Combustion Turbine #2	Oxidation catalyst and selective catalytic reduction system
EU-3	Auxiliary Boiler	Low emission burners, external flue gas recirculation

EU-1 Combustion Turbine #1 (CT1)

CT1 consists of one General Electric model 7FAe+ gas turbine (serial number 298136) and an unfired heat recovery steam generator (HRSG). The turbine drives a 60-hertz, 18-kilovolt generator (serial number 338X439). The gas turbine is designed to produce approximately 175 MW of electrical power and the steam turbine is designed to produce approximately 170 MW of electrical power (using steam from both HRSGs). The gas turbine operates primarily on natural gas, however, in the case of a natural gas curtailment, the turbine can operate on low sulfur distillate oil. When firing natural gas, the turbine has a heat input capacity of 2,067 MMBtu/hr at peak load and an estimated annual average heat input capacity of 1,782 MMBtu/hr (51 °F, 60% relative humidity). When firing fuel oil, the turbine has a heat input capacity of 2,067 MMBtu/hr at peak load and an estimated annual average heat input capacity of 1,930 MMBtu/hr (51 °F, 60% relative humidity). An inlet air fogging system was added to this unit in 2005 but subsequently removed.

Emissions from the combustion turbine consist primarily of NO_x, CO, SO₂, PM, and VOC. A Babcock-Hitachi selective catalytic reduction (SCR) system, using ~19% aqueous ammonia as a reducing reagent, controls emissions of nitrogen oxides (NO_x) and causes emissions of ammonia (NH₃). An Engelhard Corporation oxidation catalyst controls carbon monoxide (CO) emissions. Emissions of particulate matter and volatile organic compound emissions are minimized by the use of fuels with low ash contents and optimization of combustion parameters to provide for complete combustion. Combustion gases from the combustion turbine are discharged to the atmosphere through a stack measuring 19 feet 4 inches in diameter by 149 feet tall. CT1 is located to the north of CT2. The stack is located at approximately 46°37'21.09"N, 122°54'52.48"W.

The SCR is comprised of a plate-type catalyst consisting of titanium dioxide (TiO₂), molybdenum trioxide (MoO₃), and vanadium pentoxide (V₂O₅) catalytic material contained in a ceramic fiber binder. Each SCR is comprised of 72 individual blocks arranged in a 4 block wide by 18 block high configuration. Each catalyst block is 1,628 mm (5.34 ft) wide, 706 mm (2.32 ft) thick, and 946 mm (3.10 ft) high with an individual weight of 473 kg (1,043 lb). The combined volume of the 72 blocks comprising one SCR is 49.3 m³.

When the combustion turbines are fired on natural gas, the SCR NO_x removal efficiency is equal-to-or-greater-than 66.67% at an exhaust gas inlet temperature of 568°F.

The Engelhard carbon monoxide catalytic oxidation system is used to oxidize carbon monoxide (CO) to carbon dioxide (CO₂). The CO converter system consists of a honeycomb-shaped stainless steel substrate core utilizing an alumina and platinum catalytic matrix which oxidizes CO into CO₂.

Each unit includes an oxidation catalyst consisting of 250 modules. The modules are housed in a carbon steel framework and are arranged in the combustion turbine exhaust ductwork in a 10-wide by 25-high configuration. Each catalyst module weighs approximately 30 pounds and is 25.5 inches wide by 26.08 inches high and 2.452 inches deep. The frame housing the CO oxidation modules has an overall width of 24.3 feet and an overall height of 59.3 feet. Under design conditions when firing on natural gas at an ambient temperature of 51°F, the combustion turbine exhaust gas is at a nominal temperature of 627°F (+/-25°F) and the oxidation catalyst has a minimum CO-to-CO₂ conversion efficiency of 59.8%. Similarly, when firing on fuel oil at an ambient temperature of 51°F, the combustion turbine exhaust gas is at a nominal temperature of 630°F (+/-25°F) and the oxidation catalyst has a minimum CO-to-CO₂ conversion efficiency of 44.2%.

CT1 was first fired on May 25, 2003. CT1 commenced commercial operation on June 13, 2003.

CT1 is subject to 40 CFR 60 Subpart GG "Standards of Performance for Stationary Gas Turbines" because its heat input capacity at peak load exceeds 10 MMBtu/hr and it was constructed after the applicability date of October 3, 1977. The turbine has not undergone reconstruction or modification that would trigger the applicability of 40 CFR 60 Subpart KKKK "Standards of Performance for Stationary Combustion Turbines."

CAM Applicability Review

Pollutant	Uncontrolled PTE (tons)	Emission Control Device?	Emission Limit?	Subject to CAM?
NO _x	> 100	Yes	Yes	No. Permit requires CEMS.
CO	> 100	Yes	Yes	No. Permit requires CEMS.
VOC	29.24	No	Yes	No. Uncontrolled PTE < 100 tpy and no emission control device
SO ₂	43.59	No	Yes	No. Uncontrolled PTE < 100 tpy and no emission control device
PM ₁₀	> 100	No	Yes	No. No emission control device
NH ₃	> 100	No	Yes	No. Permit requires CEMS

EU-2 Combustion Turbine #2 (CT2)

CT2 consists of one General Electric model 7FAe+ gas turbine (serial number 298137) and an unfired heat recovery steam generator (HRSG). The turbine drives a 60-hertz, 18-kilovolt generator (serial number 338X440). The gas turbine is designed to produce approximately 175 MW of electrical power and the steam turbine is designed to produce approximately 170 MW of electrical power (using steam from both HRSGs). The gas turbine operates primarily on natural gas, however, in the case of

a natural gas curtailment, the turbine can operate on low sulfur distillate oil. When firing natural gas, the turbine has a heat input capacity of 2,067 MMBtu/hr at peak load and an estimated annual average heat input capacity of 1,782 MMBtu/hr (51 °F, 60% relative humidity). When firing fuel oil, the turbine has a heat input capacity of 2,067 MMBtu/hr at peak load and an estimated annual average heat input capacity of 1,930 MMBtu/hr (51 °F, 60% relative humidity). An inlet air fogging system was added to this unit in 2005 but subsequently removed.

Emissions from the combustion turbine consist primarily of NO_x, CO, SO₂, PM, and VOC. A Babcock-Hitachi selective catalytic reduction (SCR) system, using ~19% aqueous ammonia as a reducing reagent, controls emissions of nitrogen oxides (NO_x) and causes emissions of ammonia (NH₃). An Engelhard Corporation oxidation catalyst controls carbon monoxide (CO) emissions. Emissions of particulate matter and volatile organic compound emissions are minimized by the use of fuels with low ash contents and optimization of combustion parameters to provide for complete combustion. Combustion gases from the combustion turbine are discharged to the atmosphere through a stack measuring 19 feet 4 inches in diameter by 149 feet tall. CT2 is located to the south of CT1. The stack is located at approximately 46°37'19.88"N, 122°54'52.46"W.

The SCR is comprised of a plate-type catalyst consisting of titanium dioxide (TiO₂), molybdenum trioxide (MoO₃), and vanadium pentoxide (V₂O₅) catalytic material contained in a ceramic fiber binder. Each SCR is comprised of 72 individual blocks arranged in a 4 block wide by 18 block high configuration. Each catalyst block is 1,628 mm (5.34 ft) wide, 706 mm (2.32 ft) thick, and 946 mm (3.10 ft) high with an individual weight of 473 kg (1,043 lb). The combined volume of the 72 blocks comprising one SCR is 49.3 m³.

When the combustion turbines are fired on natural gas, the SCR NO_x removal efficiency is equal-to-or-greater-than 66.67% at an exhaust gas inlet temperature of 568°F.

The Engelhard carbon monoxide catalytic oxidation system is used to oxidize carbon monoxide (CO) to carbon dioxide (CO₂). The CO converter system consists of a honeycomb-shaped stainless steel substrate core utilizing an alumina and platinum catalytic matrix which oxidizes CO into CO₂.

Each unit includes an oxidation catalyst consisting of 250 modules. The modules are housed in a carbon steel framework and are arranged in the combustion turbine exhaust ductwork in a 10-wide by 25-high configuration. Each catalyst module weighs approximately 30 pounds and is 25.5 inches wide by 26.08 inches high and 2.452 inches deep. The frame housing the CO oxidation modules has an overall width of 24.3 feet and an overall height of 59.3 feet. Under design conditions when firing on natural gas at an ambient temperature of 51°F, the combustion turbine exhaust gas is at a nominal temperature of 627°F (+/-25°F) and the oxidation catalyst has a minimum CO-to-CO₂ conversion efficiency of 59.8%. Similarly, when firing on fuel oil at an ambient temperature of 51°F, the combustion turbine exhaust gas is at a nominal temperature of 630°F (+/-25°F) and the oxidation catalyst has a minimum CO-to-CO₂ conversion efficiency of 44.2%.

CT2 was first fired on May 31, 2003. CT2 commenced commercial operation on June 5, 2003.

CT2 is subject to 40 CFR 60 Subpart GG "Standards of Performance for Stationary Gas Turbines" because its heat input capacity at peak load exceeds 10 MMBtu/hr and it was constructed after the

applicability date of October 3, 1977. The turbine has not undergone reconstruction or modification that would trigger the applicability of 40 CFR 60 Subpart KKKK "Standards of Performance for Stationary Combustion Turbines."

CAM Applicability Review

Pollutant	Uncontrolled PTE (tons)	Emission Control Device?	Emission Limit?	Subject to CAM?
NO _x	> 100	Yes	Yes	No. Permit requires CEMS.
CO	> 100	Yes	Yes	No. Permit requires CEMS.
VOC	29.24	No	Yes	No. Uncontrolled PTE < 100 tpy and no emission control device
SO ₂	43.59	No	Yes	No. Uncontrolled PTE < 100 tpy and no emission control device
PM ₁₀	> 100	No	Yes	No. No emission control device
NH ₃	> 100	No	Yes	No. Permit requires CEMS

EU-3 Auxiliary Boiler

Installation of the Auxiliary Boiler was required by Council Order #836 authorizing the transfer of the Chehalis Generation Facility Site Certification Agreement to PacifiCorp. On September 15, 2008 EFSEC received notice that the Chehalis Generation Facility had been merged into PacifiCorp. The Auxiliary Boiler is used to provide steam to the gas turbine generators' support equipment and to reduce the required duration of gas turbine startup events.

The Auxiliary Boiler is a natural gas fired CB NAT-COM package boiler utilizing a low-NO_x model P-17-G-14-0911 burner set. The boiler was built, installed, and commissioned in 2010. The following equipment details were available:

Location: South of main building, between main building and the air cooled condensers

Startup Date: December 8, 2010

Make / Model: Cleaver Brooks – NATCOM / NB-200D-35

Fuel: Natural gas

Heat Input Capacity: 16.9 MMBtu/hr

Burners: Model P-17-G-14-0911, serial number 11497, designed to provide ≤ 9 ppmvd NO_x @ 3% O₂ utilizing external flue gas recirculation.

Stack Description: Exhausts vertically through stack measuring 30" diameter, 88' above grade, 28.1 ft/s, 200 °F. The tallest adjacent structure is 76.75' above grade. Located at approximately 46°37'18.17"N, 122°54'53.56"W

The Auxiliary Boiler is subject to the 40 CFR 60 Subpart Dc "Standards of Performance for Small Industrial-Commercial-Institutional Steam Generating Units" because its heat input capacity is less than 100 MMBtu/hr and equal to or greater than 10 MMBtu/hr and it was constructed after the applicability date of June 9, 1989.

CAM Applicability Review

Pollutant	Uncontrolled PTE (tons)	Emission Control Device?	Emission Limit?	Subject to CAM?
NO _x	1.08	No	Yes	No. Uncontrolled PTE < 100 tpy and no emission control device
CO	2.73	No	Yes	No. Uncontrolled PTE < 100 tpy and no emission control device
VOC	0.30	No	Yes	No. Uncontrolled PTE < 100 tpy and no emission control device
SO ₂	0.41	No	Yes	No. Uncontrolled PTE < 100 tpy and no emission control device
PM ₁₀	1.31	No	Yes	No. Uncontrolled PTE < 100 tpy and no emission control device

III. EXPLANATION OF INSIGNIFICANT EMISSIONS UNIT DETERMINATIONS

The following equipment was identified by the permittee as insignificant. Each emission unit listed as insignificant in the permit has been reviewed by EFSEC to confirm its status. None of the listed equipment is a significant source of emissions or is subject to any equipment specific air quality requirements.

Equipment Description	Size or Capacity	Justification
Fuel Oil (#2 diesel) piping fugitive emissions	Not applicable	WAC 173-401-530(1)(d) – only fugitive emissions
Fuel Oil Storage Tanks (two tanks)	1,700,000 gallons each	WAC 173-401-530(1)(c) – actual vapor pressure less than 5 mm Hg @ 21°C (category listed in WAC 173-533(2)(t)).
Natural Gas Piping	Not applicable	WAC 173-401-530(1)(d) – only fugitive emissions
Inlet Gas Drain Tank	250 gallons	WAC 173-401-530(1)(a) – below emissions thresholds
19% Aqueous Ammonia Storage Tanks	32,000 gallons	WAC 173-401-530(1)(a) – below emissions thresholds
Oil/Water Separator	<500 gallons	WAC 173-401-530(1)(b) – actual vapor pressure less than 550 mm Hg @ 21°C, tank less than 1,100 gallons (category listed in WAC 173-533(2)(b)).
Waste Oil Tank (as separator)	150 gallons	WAC 173-401-530(1)(b) – actual vapor pressure less than 550 mm Hg @ 21 °C, tank less than 1,100 gallons (category listed in WAC 173-533(2)(b)).
Waste Fuel Drain Tanks (2)	500 gallons each	WAC 173-401-530(1)(b) – actual vapor pressure less than 550 mm Hg @ 21°C, tank less than 1,100 gallons (category listed in WAC 173-533(2)(b)).

Equipment Description	Size or Capacity	Justification
Miscellaneous Wastewater Collection Sumps	1,000 – 2,500 gallons each	WAC 173-401-530(1)(b) – categorically exempt equipment listed in WAC 173-401-532(120)
Sanitary Waste Storage Area	3,100 gallons	WAC 173-401-530(1)(b) – categorically exempt as per WAC 173-401-532(6)
Lubricating oil storage tanks	Not applicable	WAC 173-401-530(1)(b) – categorically exempt as per WAC 173-401-532(3)
Pressurized storage tanks containing oxygen, nitrogen, carbon dioxide or inert gases	Not applicable	WAC 173-401-530(1)(b) – categorically exempt as per WAC 173-401-532(5)
Vents from continuous emissions monitors and analyzers	Not applicable	WAC 173-401-530(1)(b) – categorically exempt as per WAC 173-401-532(8)

IV. EXPLANATION OF SELECTED PERMIT PROVISIONS AND GENERAL TERMS AND CONDITIONS

G2. Chemical Accident Prevention

Part 68 requires risk management plans be developed for the substances and thresholds listed in 40 CFR 68.130. Ammonia is a listed substance. The SNCR system utilizes urea rather than ammonia. The permittee uses no other substance listed in 40 CFR 68.130, therefore this standard does currently not apply to this facility.

V. EXPLANATION OF OPERATING TERMS AND CONDITIONS

Req. 1-8 General Standards for Maximum Emissions

[WAC 173-400-040]

WAC 173-400-040 establishes maximum emission standards for various air contaminants. These requirements are general statewide standards, and apply to all sources of air contaminants. Therefore, these requirements apply to all emission units at the source, both EU and IEU. Pursuant to WAC 173-401-530(2)(c), the permit does not contain any testing, monitoring, recordkeeping, or reporting requirements for IEUs except those specifically identified by the underlying requirements.

Req-6 prohibits any concealment or masking. At present, the permittee does not operate any equipment capable of masking emissions, therefore monitoring is limited to the annual compliance certification.

Note that the 1,000 ppmvd SO₂ @ 7% O₂ limitation from WAC 173-400-040(7) cannot be exceeded if the facility burns the approved fuels, therefore no monitoring beyond confirming the fuel type is necessary:

Maximum SO₂ emissions from burning natural gas can be calculated assuming a maximum sulfur content of 20 gr/100 scf. This concentration far exceeds the expected sulfur content of approximately

0.5 gr/100scf. 20 gr/100 scf is the maximum sulfur tariff for most pipelines and matches the maximum sulfur included under the definition of "natural gas" in 40 CFR 72.

$$\left(\frac{20 \text{ gr}}{100 \text{ ft}^3 \text{ nat. gas}}\right) \left(\frac{1 \text{ ft}^3 \text{ nat. gas}}{1,020 \text{ Btu}}\right) \left(\frac{64 \text{ lbs SO}_2}{32 \text{ lbs S}}\right) \left(\frac{1 \text{ lb}}{7,000 \text{ gr}}\right) \left(\frac{10^6 \text{ Btu}}{8,710 \text{ dscf}}\right) \left(\frac{20.9 - 7\% \text{ O}_2}{20.9\% \text{ O}_2}\right) \left(\frac{1 \text{ lbmol SO}_2}{64 \text{ lbs SO}_2}\right) \left(\frac{385 \text{ ft}^3 \text{ SO}_2}{1 \text{ lbmol SO}_2}\right)$$

$$= \left(\frac{26 \text{ ft}^3 \text{ SO}_2}{10^6 \text{ ft}^3 \text{ Exhaust}}\right) = 26 \text{ ppm @ } 7\% \text{ O}_2$$

When firing distillate oil in the turbines, the maximum allowed fuel sulfur content in the permit is 0.05%. Maximum SO₂ emissions from burning 0.05% sulfur fuel:

$$\left(\frac{0.05 \text{ lb S}}{100 \text{ lbs fuel}}\right) \left(\frac{7.206 \text{ lbs fuel}}{1 \text{ gallon fuel}}\right) \left(\frac{1 \text{ gallon fuel}}{0.138 \text{ MMBtu}}\right) \left(\frac{64 \text{ lbs SO}_2}{32 \text{ lbs S}}\right) \left(\frac{\text{MMBtu}}{9,190 \text{ dscf}}\right) \left(\frac{20.9 - 7\% \text{ O}_2}{20.9\% \text{ O}_2}\right) \left(\frac{1 \text{ lbmol SO}_2}{64 \text{ lbs SO}_2}\right) \left(\frac{385 \text{ ft}^3 \text{ SO}_2}{1 \text{ lbmol SO}_2}\right)$$

$$= \left(\frac{0.68 \text{ ft}^3 \text{ SO}_2}{10^6 \text{ ft}^3 \text{ Exhaust}}\right) = 22.7 \text{ ppm @ } 7\% \text{ O}_2$$

Req. 9 Emission Standards for General Process Units

WAC 173-400-060 establishes maximum particulate matter emission standards for general process units. These requirements apply to any general process units at the source, including IEUs. The definition of a "general process unit" excludes combustion units; therefore this requirement does not apply to the exhaust stacks of EU-1, EU-2, or EU-3. Pursuant to WAC 173-401-530(2)(c), the permit does not contain any testing, monitoring, recordkeeping, or reporting requirements for IEUs except those specifically identified by the requirements as applying to IEUs.

At the current time, no general process units have been identified at this facility with the potential to emit particulate matter. This requirement was included in the permit to apply to operations not currently identified or not yet installed at the facility.

Req. 10 Good Air Pollution Control Practices

40 CFR 60.11(d) requires that applicable equipment (the combustion turbines and auxiliary boiler in this case) be operated in a manner consistent with good air pollution control practices for minimizing emissions. This requirement applies to the New Source Performance Standards (NSPS) for the turbines (Subpart GG) and the Auxiliary Boiler (Subpart Dc). This requirement is particularly important during startup, shutdown, and upset periods when the equipment cannot comply with the permit limits that apply during normal operation. 40 CFR 60.11(d) does not explain how to implement this standard, however EFSEC believes that this requirement should be interpreted consistent with more recent MACT/NESHAP rulemakings in which EPA writes "The general duty to minimize emissions does not require the owner or operator to make any further efforts to reduce emissions if levels required by the applicable standard have been achieved." Consistent with this interpretation, this requirement is reviewed when there is an exceedance of a relevant NSPS limit.

Req. 11 Combustion Turbine Fuel Sulfur Limit

40 CFR 60 Subpart GG limits the sulfur content of fuel burned in applicable combustion turbines to 0.8% by weight. The combustion turbines are only approved to burn "natural gas" and "on-

road specification diesel fuel" (oil) containing no more than 0.05% sulfur by weight..." 20 gr/100 scf is the maximum sulfur tariff for most pipelines and matches the maximum sulfur included under the definition of "natural gas" in 40 CFR 72. 20 gr/100 scf is equivalent to approximately 0.025% by weight. Therefore, the facility will be in compliance with this requirement if burning either of the approved fuels.

Req. 12 – Fuel Firing Restrictions

Conditions 1.1 and 1.2 of EFSEC/95-02 Amendment 2 requires that the combustion turbines be fired on natural gas except when natural gas is not available and during limited test periods. "On-road specification diesel fuel" may be burned during these periods.

"On-road specification diesel fuel" refers to the on-road specifications from 40 CFR 80.29 as amended through July 1, 1992.

Hours of operation on oil for test periods and startup count towards the 720 hour limit of operation on oil.

Req. 13 – NO_x Emission Limits

Conditions 2.1, 2.2, and 2.3 of EFSEC/95-02 Amendment 2 provide NO_x emission limits during both natural gas and oil firing. In accordance with Condition 24 of EFSEC/95-02 Amendment 2, these limits apply on a CEM clock hour or calendar day basis when the CEMS is being used to measure emissions. For days when a turbine is fired on both natural gas and oil, a time-weighted average of the gas and oil firing emission limits applies. The last sentence in this requirement states that the oil-firing limit applies for any hour in which oil is fired. It is not practical to split up emission limits into fractions of an hour according to which fuel is being burned, therefore it was determined that the emission limit would need to apply to any hour in which fuel oil is burned.

40 CFR 60.332(a)(1) provides a parallel NO_x emission limit for combustion turbines, however this limit is far less restrictive than the limits provided by Conditions 2.1 and 2.2 of EFSEC/95-02 Amendment 2. Compliance with the emission limits of Conditions 2.1 and 2.2 will assure compliance with the NO_x emission limit in 40 CFR 60.332(a)(1), therefore only the limits from Conditions 2.1 and 2.2 were listed. 40 CFR 60.332(a)(1) provides for a limit of at least 75 ppmvd @ 15% O₂ (the limit can increase based on the magnitude of any fuel-bound nitrogen allowance and the manufacturer's rated heat rate at manufacturer's rated load).

Req. 14 – CO Emission Limits

Conditions 3.1 and 3.2 of EFSEC/95-02 Amendment 2 provide CO emission limits during both natural gas and oil firing. In accordance with Condition 24 of EFSEC/95-02 Amendment 2, these limits apply on a CEM clock hour or calendar day basis when the CEMS is being used to measure emissions. The last sentence in this requirement states that the oil-firing limit applies for any hour in which oil is fired. It is not practical to split up emission limits into fractions of an hour according to which fuel is being burned, therefore it was determined that the emission limit would need to apply to any hour in which fuel oil is burned.

Req. 15 – SO₂ Emission Limits

Conditions 4.1 and 4.2 of EFSEC/95-02 Amendment 2 provide SO₂ emission limits during both natural gas and oil firing. The last sentence in this requirement states that the oil-firing limit applies for any hour in which oil is fired. It is not practical to split up emission limits into fractions of an hour according to which fuel is being burned, therefore it was determined that the emission limit would need to apply to any hour in which fuel oil is burned.

Req. 16 – VOC Emission Limits

Conditions 5.1 and 5.2 of EFSEC/95-02 Amendment 2 provide VOC emission limits during both natural gas and oil firing. Because the term "volatile organic compounds" (VOCs) describes a large class of compounds, a standard compound (in this case propane) must be used in order to compare emission limits and source test results using EPA Method 25A. If the relative concentrations of each volatile organic species is known, the actual emission rate of each species and the total emission rate of VOCs can be determined. VOC speciation data is not required.

For days when a turbine is fired on both natural gas and oil, a time-weighted average of the gas and oil firing emission limits applies. The last sentence in this requirement states that the oil-firing limit applies for any hour in which oil is fired. It is not practical to split up emission limits into fractions of an hour according to which fuel is being burned, therefore it was determined that the emission limit would need to apply to any hour in which fuel oil is burned.

Req. 17 – PM₁₀ Emission Limits

Conditions 6.1 and 6.2 of EFSEC/95-02 Amendment 2 provide PM₁₀ emission limits during both natural gas and oil firing. EPA Method 5 was listed as a possible reference test method because it is presumed that all particulate matter generated from this source will have an aerodynamic diameter of 10 µm or less. EPA Method 201A would be considered a superior test method for the determination of PM₁₀, but is not required due to inherent method limitations and the fact that all particulate matter is expected to be PM₁₀. This permit limit is based solely on the filterable component of PM₁₀ and does not require consideration or testing of the condensable fraction of PM₁₀.

For days when a turbine is fired on both natural gas and oil, a time-weighted average of the gas and oil firing emission limits applies.

Req. 18 – Sulfuric Acid Emission Limit

Conditions 7.1 and 7.2 of EFSEC/95-02 Amendment 2 limits sulfuric acid emissions from EU-1 and EU-2. Because of the interference caused by ammonia in the exhaust gas, EPA Method 8 cannot be used without modification to measure sulfuric acid emissions.

The last sentence in this requirement states that the oil-firing limit applies for any hour in which oil is fired. It is not practical to split up emission limits into fractions of an hour according to which fuel is being burned, therefore it was determined that the emission limit would need to apply to any hour in which fuel oil is burned.

Req. 19 – Opacity Limit

Condition 8 of EFSEC/95-02 Amendment 2 limit opacity from the HRSG exhaust stacks to 10 percent or less on a 6-minute average. EPA Method 9 or an equivalent method must be used daily to confirm compliance. When no visible emissions are present, EPA Method 22 is an equivalent method. Both EPA Method 9 (which requires a certified observer) and EPA Method 22 can be used to determine the presence or absence of visible emissions. The presence of visible emissions is highly unlikely at this facility, except during periods of extreme upset conditions.

Req. 20 – Ammonia Emission Limits

Conditions 9.1, 9.2, 9.3, and 9.4 of EFSEC/95-02 Amendment 2 limits ammonia emissions from EU-1 and EU-2. For days when a turbine is fired on both natural gas and oil, a time-weighted average of the gas and oil firing emission limits applies.

Req. 21, 22 – Startup and Shutdown Provisions

Conditions 10.2, 10.3, 10.6, and 10.7 of EFSEC/95-02 Amendment 2 provide for special provisions regarding the duration and number of combustion turbine startup and shutdown events because during startup and shutdown the combustion turbines cannot meet all the emission limits that apply during normal operation. Alternative CO and NO_x emission limits are provided by Conditions 10.4 and 10.5 of EFSEC/95-01 Amendment 2. These alternative limits only apply during the startup and shutdown periods defined in Condition 10.6 of EFSEC/95-01 Amendment 2.

The number of startups per 24-hour period and per year were not limited to assure compliance with ambient air impact limitations. The limits on the number of startups apply to normal startups. Startups resulting from upset conditions (e.g. after emergency shutdowns or unit trips) do not count towards the limitations provided in Conditions 10.2 and 10.3. After a unit trip, the unit can often return to service quickly; to require an extended period of time to elapse before allowing it to return to service (e.g. to get outside of a 1-day period with two startups) could result in a longer cooling period and a longer startup resulting in greater overall emissions.

Condition 10.3 of EFSEC/95-02 Amendment 2 reads: "Each CGT is limited to a maximum of 2 startup and shutdown events per 24 hour period." This wording has been analyzed in context and EFSEC believes the term "24 hour period" was intended to refer to a block period rather than a rolling 24-hour period for the following reasons:

1. Rolling periods are typically clearly denoted as such.
2. A 24-hour block (daily) total would be consistent with Condition 24 of the permit that reads: "Hourly and daily averaging periods throughout this permit may be based on clock hours and calendar days."
3. Compliance with "24-hour" federal standards are commonly determined on a 24-hour block (daily) average. Examples includes 40 CFR 60 Subparts Da and AAAA, and 40 CFR 63 Subpart W. This is clearly illustrated in the definitions section of 40 CFR 60 Subpart Da: "*24-hour period* means the period of time between 12:01 a.m. and 12:00 midnight."
4. The original PSD permit for Grays Harbor Energy, written by the same staff during the same time period, contained the same restrictions "...2 startups per turbine per 24-hour

period." The condition was later changed to "Each CGT is limited to 2 warm startup and shutdown events per calendar day" in a permit revision unrelated to this condition.

5. A 24-hour block (daily) total would be consistent with the time period of ambient monitoring protocols.
6. Most likely the condition was imposed to limit the impact on visibility in Class 1 areas. It is highly unlikely that the model that was used (CalPuff) was run on anything other than a calendar day basis in this time period. Startup emissions did not threaten any ambient air quality standard.

Req. 23 – Sampling Ports and Platforms

This requirement from the PSD permit is similar to the requirement in 40 CFR 60.8(e) regarding minimum performance testing facilities. This facility has been constructed with sample ports and a test platforms that meet the requirements of the PSD permit and 40 CFR 60.8(e).

Req. 24 – Source Emission Sampling Access

40 CFR 60.8(e) requires the owner or operator of an NSPS applicable unit to provide safe access to adequate test ports, and the utilities necessary to conduct applicable sampling required of NSPS applicable units. Both turbines are subject to 40 CFR 60 Subpart GG, and therefore such access is required for the performance of EPA Method 20. Condition 13 of EFSEC/95-02 Amendment 2 requires safe access to test ports, but does not mention providing testing utilities. The sentence in Req. 23 concerning utilities is solely from 40 CFR 60.8(e).

Req. 25 – Operating and Maintenance Manuals

Condition 19 of EFSEC/95-02 Amendment 2 requires the permittee to maintain operation and maintenance manuals for equipment at the facility that can affect emissions. Operations and maintenance manuals may be used to investigate excess emissions events and determine if such events were avoidable. Reasonable inquiry conducted for the annual compliance certification is adequate to assure that these manuals are maintained at the facility.

Req. 26 – SO₂ Allowances

40 CFR 72.9 and WAC 173-406-106 require that the facility hold SO₂ allowances not less than the total annual emissions in tons of SO₂ from the affected units (CT1 and CT2).

Req. 27 – Auxiliary Boiler Emission Limits

Condition 1 of EFSEC/2009-01 establishes concentration emission limits for NO_x and CO and mass emission limits for PM₁₀ and PM_{2.5}. The emission limits are based on reference method testing that is conducted utilizing 1-hour test runs, therefore the Title V permit clarifies that these emission limits apply on one-hour averages.

The PM₁₀ and PM_{2.5} mass emission rate limits are based on total PM emissions (filterable and condensable utilizing EPA Methods 201A and 202). Because natural gas combustion is expected to only produce fine particulate matter, EPA Method 5 can be used in place of EPA Method 201A to measure filterable particulate matter if all PM measured using EPA Method 5 is assumed to be

PM_{2.5}. PM₁₀ and PM_{2.5} mass emission rate limits are based on a 30 MMBtu/hr boiler, however only a 16.9 MMBtu/hr boiler was installed, therefore compliance with these limits will presumably be by a large margin.

Req. 28 – Auxiliary Boiler Visual Emissions Limit

Condition 2 of EFSEC/2009-01 establishes a zero percent opacity limit (not to be exceeded for more than 3 minutes in any one hour period). EPA Method 9 is cited as the monitoring method; however Ecology Method 9A is the method that must be used for the data reduction to determine compliance with this limitation. The data reduction utilized by EPA Method 9 is utilized for determining average opacity. The data reduction of Ecology Method 9A is used to determine compliance with three minute standards such as Condition 2.

Req. 29 – Auxiliary Boiler Fuel Limitation

Natural gas was the only fuel reviewed for use by the Auxiliary Boiler and therefore the only fuel approved for use under the New Source Review permit. No specific monitoring is necessary to demonstrate compliance because compliance can be determined by physically inspecting the boiler.

VI. EXPLANATION OF MONITORING AND RECORDKEEPING TERMS AND CONDITIONS

M1. General Recordkeeping

This recordkeeping section lists how the recordkeeping requirements of WAC 173-401-615(2) apply to inspections and certifications, complaints, upsets, and sampling and emissions testing. Basic Recordkeeping requirements were separated into Sections (a) through (h) to organize the requirements.

M1(c) "Sampling and Emission Testing" applies to source testing and RATA reports.

M2. Visible Emission Monitoring

This monitoring requirement is used to provide a reasonable assurance of compliance with the applicable requirements drawn from WAC 173-400, and EFSEC/95-02 Amendment 2. Visible emissions monitoring of EU-1 and EU-2 is required by Condition 8 of EFSEC/95-02 Amendment 2. Condition 8 requires daily monitoring when firing oil, or weekly monitoring when firing natural gas, utilizing EPA Reference Methods 9, 22, or an equivalent method approved by EFSEC. EPA Method 22 may be used when no visible emissions are observed. It is expected that no visible emissions will be observable during normal operations.

Because EPA Method 9 cannot be used to demonstrate compliance with the 20% opacity standard listed in WAC 173-400-040(1), Washington Department of Ecology Method 9A must be utilized in addition to EPA Method 9 whenever visible emissions are observed when conducting the daily monitoring. This monitoring was added under the "gap-filling" provisions of WAC 173-401. The only significant difference in these two methods is the data reduction methods and the fact that Washington Department of Ecology Method 9A may require a longer period of observation to demonstrate compliance with the opacity standard.

Only the general standards of WAC 173-400 apply to sources of emissions other than EU-1 and EU-2. WAC 173-400 does not directly establish any specific regime of monitoring and recordkeeping. Consequently, EFSEC has implemented monitoring and recordkeeping requirements for these sources under the "gap filling" provisions of WAC 173-401-615. These requirements consist of measuring the opacity of emissions from these sources when indicated by a complaint or if otherwise unusual emissions are observed.

M3. Fugitive Emissions Monitoring

This monitoring requirement is used to provide a reasonable assurance of compliance with the applicable requirements drawn from WAC 173-400 with regard to fugitive emissions. These requirements do not directly establish any specific regime of fugitive emissions monitoring or recordkeeping. Consequently, EFSEC has implemented monitoring and recordkeeping requirements under the "gap filling" provisions of WAC 173-401-615. Because there is not much opportunity for the generation of fugitive emissions at this facility, and most fugitive emissions would be readily noticeable by plant personnel or indicated by a complaint (especially in the event of excessive road dust), monthly monitoring was believed to provide a reasonable assure of compliance.

M2 is designed to assure compliance through a combination of periodic facility inspections and prompt corrective action whenever necessary.

M4. Complaint Monitoring

This monitoring requirement is used to provide a reasonable assurance of compliance with the applicable requirements drawn from WAC 173-400 and EFSEC/95-02 Amendment 2. These requirements do not directly establish any specific regime of complaint monitoring or recordkeeping. Consequently, EFSEC has implemented monitoring and recordkeeping requirements under the "gap filling" provisions of WAC 173-401-615. M3 is designed to assure compliance through prompt complaint response and corrective action whenever necessary.

M5. Performance Testing

This monitoring requirement is used to provide a reasonable assurance of compliance with the emission limits identified in EFSEC/95-02 Amendment 2. Initial source testing for 40 CFR 60 Subpart GG, and all initial testing required by EFSEC/95-02 Amendment 2 was completed in August 2003. The only on-going source testing requirements are found in Condition 15 of EFSEC/95-02 Amendment 2.

M6. Continuous Emissions and Process Monitoring

This monitoring requirement is used to provide a reasonable assurance of compliance with the emission limits identified in EFSEC/95-02 Amendment 2 and the monitoring requirements of 40 CFR 75 (for the Acid Rain program).

EFSEC/95-02 Amendment 2 stated that CEMS for NO_x and O₂, "shall meet the requirements contained in 40 CFR 75, Emissions Monitoring." 40 CFR 75 was designed to achieve the goals of the Acid Rain Program, not demonstrate compliance with the relatively low concentration permit limit of 3.0 ppmvd @ 15% O₂ at this facility. 40 CFR 75 allows for NO_x/O₂ CEMS to have a relative accuracy of 0.020 lb/MMBtu (5.4 ppmvd @ 15% O₂). Similarly, 40 CFR 75 App. B Section 2.1.4(a) does not classify the CEMS as "out of control" until the calibration error exceeds 5.0 ppm (for span values ≤ 50 ppm), or 10.0 ppm (for span values greater than 50 and ≤ 200 ppm). A NO_x/O₂ CEMS needs to be more accurate than this to provide a reasonable assurance of compliance with the 3.0 ppmvd @ 15% O₂ permit limit.

The quality assurance requirements cited in EFSEC/95-02 Amendment 2 for the CO CEMS allow for a relative accuracy of ±5 ppm and a cylinder gas audit accuracy of ±5 ppm. The CO CEMS needs to be more accurate than this to provide a reasonable assurance of compliance with the 3.0 ppmvd @ 15% O₂ permit limit.

The quality assurance requirements cited in EFSEC/95-02 Amendment 2 for the NH₃ CEMS allows for a cylinder gas audit accuracy of ±5 ppm. The NH₃ CEMS needs to be more accurate than this to provide a reasonable assurance of compliance with the 10.0 ppmvd @ 15% O₂ permit limit.

WAC 173-401-630(1) requires that all Air Operating Permits "...contain compliance certification, testing, monitoring, reporting, and recordkeeping requirements sufficient to assure compliance with the terms and conditions of the permit." To meet this requirement, the following improved CEMS quality assurance requirements were "gap-filled" into the Air Operating Permit.

CEMS	Gap-Filled Quality Assurance Requirements
NO _x /O ₂	<ul style="list-style-type: none"> Relative accuracy ≤ 20% of reference method or 10% of emission standard for Relative Accuracy Test Audits The calibration error as defined in 40 CFR 75, Appendix A, Section 7.2.1 must not exceed 5%
CO	<ul style="list-style-type: none"> Relative accuracy ≤ 20% of reference method or 10% of emission standard for Relative Accuracy Test Audits Relative accuracy of cylinder gas audit ±15 percent of the average audit value or 0.5 ppm, whichever is greater
NH ₃	<ul style="list-style-type: none"> Relative accuracy of cylinder gas audit ±15 percent of the average audit value or 1.0 ppm, whichever is greater

Summary of RATA Requirements

Parameter	Units	Standard
NO _x /O ₂	ppmvd NO _x @ 15% O ₂	20% Relative Accuracy when the average reference method value is used in the denominator of Equation A-10 of 40 CFR 75; or a Relative Accuracy of 10% when the applicable emission standard (3.0 ppmvd @ 15% O ₂) is used in the denominator of Equation A-10 of 40 CFR 75 in place of the arithmetic mean of the reference method values.
NO _x /O ₂	lb/MMBtu	7.5% < RA ≤ 10.0% or ±0.020 lb/mmBtu for semi-annual test frequency, RA ≤ 7.5% or ±0.015 lb/mmBtu for annual test frequency [40 CFR 75, Appendix B]
O ₂	%vd	7.5% < RA ≤ 10.0% or ±1.0% CO ₂ /O ₂ for semi-annual test frequency, RA ≤ 7.5% or ±0.7% CO ₂ /O ₂ for annual test frequency [40 CFR 75, Appendix B]
CO	ppmvd @ 15% O ₂	20% Relative Accuracy when the average reference method value is used in the denominator of Equation 2-6 of 40 CFR 60, Performance Specification 2; or a Relative Accuracy of 10% when the applicable emission standard is used in the denominator of Equation 2-6 of 40 CFR 60, Performance Specification 2.
NH ₃	ppmvd @ 15% O ₂	

EFSEC/95-02 Amendment 2 identified the "requirements contained in 40 CFR, Part 60, Appendix B..." for the CO CEMS. The most relevant performance standard in Appendix B is Performance Specification 4A, therefore the requirements of Performance Specification 4A were specifically identified in this monitoring requirement.

EFSEC/95-02 Amendment 2 identified the "requirements contained in 40 CFR, Part 60, Appendix B..." for the NH₃ CEMS. The most relevant performance standard in Appendix B is Performance Specification 2, therefore the requirements of Performance Specification 2 were specifically identified in this monitoring requirement.

Condition 16 of EFSEC/95-02 Amendment 2 requires the permittee to report "CEMS and process data" to EFSEC and EPA Region X. To be reported, this information must be collected by the permittee. The specific CEMS and process data elements were not identified, but must at a minimum, consist of all data necessary to determine compliance with the permitted emission limits. Collection of the relevant CEMS data for NO_x, CO, and NH₃ were required (in units and averaging times consistent with the emission limits), as well as fuel flow data to calculate emissions of all other pollutants. Turbine generator electrical output was required as a quality assurance check on the fuel flow data since turbine heat rates should remain relatively constant at any specific load.

The Acid Rain Program requires that pertinent records be maintained for at least three years from the date of the record. However, the recordkeeping provisions of the Air Operating Permit regulations, WAC 173-401-615(2)(c), require retention of records for a period of five years.

The requirement to maintain records of the CEMS and DAHS data that is required to be collected is mandated by the provisions of WAC 173-401-615(2).

M7. SO₂ General Standard Monitoring

This monitoring requirement is used to provide a reasonable assurance of compliance with the applicable requirements drawn from 40 CFR 60 Subpart GG, 40 CFR 75, and EFSEC/95-02 Amendment 2. 40 CFR 60 Subpart GG limits fuel sulfur content to 0.8% by weight. 40 CFR 60 Subpart GG requires proof that gaseous fuel meet the definition of natural gas, and requires a regime of fuel sulfur content monitoring for liquid fuels (oil). All of the sulfur content monitoring requirements of 40 CFR 60 Subpart GG are satisfied by complying with the sulfur content monitoring requirements of 40 CFR 75 Appendix D.

Pipeline natural gas as defined in 40 CFR 72.2 contains less than 0.5 grains total sulfur per 100 scf. Natural gas as defined in 40 CFR 72.2 contains less than 20 grains total sulfur per 100 scf. In the past, there have been time during which the gas delivered to this facility has met the definition of natural gas, but not pipeline natural gas because the sulfur content was greater than 0.5 grains per 100 scf.

M8. Auxiliary Boiler Monitoring

This monitoring requirement comes directly from 40 CFR 60.48c and EFSEC/2009-01 Conditions 4 and 5. 40 CFR 60.48c and EFSEC/2009-01 Condition 4 both require monthly logging of natural gas consumption. This data will be used to calculate annual emissions.

M9. Auxiliary Boiler Source Emissions Testing and Performance Monitoring

The requirements cited in this monitoring requirement and Appendices B & C of the Permit come directly from EFSEC/2009-01 and provide a reasonable assurance of compliance with the NO_x and CO emission limits of EFSEC/2009-01. In addition, if the CO emission limit is being achieved, PM emissions are likely well below the permitted emission limits.

Performance monitoring of the Auxiliary Boiler with a combustion analyzer or equivalent is required at least annually. It is unlikely that emissions will degrade rapidly enough that more frequent monitoring is necessary to maintain proper operation. In addition, more comprehensive source emissions testing of the Auxiliary Boiler is required initially and at least once every 60 months following the initial source emissions test to provide a reasonable assurance of on-going compliance with the permitted emission limits

VII. EXPLANATION OF REPORTING REQUIREMENTS

R1. Deviations from Permit Conditions

This reporting section is taken directly from WAC 173-400-107, WAC 173-401-615(3), and Condition 18 of EFSEC/95-02 Amendment 2. The permittee is required to report all permit deviations no later than 30 days following the end of the month during which the deviation is discovered in accordance with WAC 173-401-615(3). In accordance with WAC 173-400-

107, the permittee must report permit deviations due to excess emissions as soon as possible if the permittee wishes the deviation to be considered unavoidable. EFSEC may request a full report of any deviation if determined necessary. These deviations are also reported in each semi-annual report.

R2. Complaint Reports

The permittee is required to report all complaints to EFSEC within three business days of receipt to ensure prompt complaint response. This reporting section is based on WAC 173-401-615(3).

R3. Quarterly Reports

Condition 16 of EFSEC/95-02 Amendment 2 requires the permittee to submit reports monthly unless a different testing and reporting schedule has been approved by EFSEC. With issuance of this Title V permit, EFSEC authorizes the use of a quarterly reporting schedule rather than a monthly reporting schedule for the duration of the permit. In addition, with issuance of this Title V permit, EFSEC authorizes the permittee to submit quarterly reports in an electronic format approved by EFSEC. The current practice of submitting quarterly reports in Excel format is approved as of the date of issuance of this permit. The permittee must receive pre-approval from EFSEC to submit the quarterly report in other electronic formats.

As required by EFSEC/95-02 Amendment 2, all CEMS and process data must be reported to both EFSEC and EPA Region X. The specific CEMS and process data elements were not identified, but must at a minimum, consist of all data necessary to determine compliance with the permitted emission limits. The relevant CEMS data for NO_x, CO, and NH₃ was required (in the units and averaging times of the emission limits), as well as fuel flow data to calculate emissions of all other pollutants. Turbine generator electrical output was required as a quality assurance check on the fuel flow data since turbine heat rates should remain relatively constant at a specific load.

R4. Semi-annual Reports

The permittee is required to provide a report on the status of all required monitoring requirements and provide a certification of all reports on a semi-annual basis. Semi-annual reporting and certification of monitoring records is required by WAC 173-401-615(3). A responsible official must certify all reports required by the Title V permit.

The semi-annual report provides information on the status of all required monitoring. The actual results (e.g. CEM data, opacity readings, etc.) do not need to be submitted unless specifically required by the permit.

No report dates are specified in WAC 173-401-615(3), but a report date must be specified to assure timely reporting and make the requirement enforceable. Report dates of April 15th and October 15th were chosen (~3.5 months after the end of the reporting period) so that the semi-annual report for the last six months of the calendar year is due at the same time as the annual compliance certification and the annual emissions inventory report.

R5. Annual Compliance Certifications

Annual Compliance Certification: The permittee is required to report and certify compliance with all permit terms and conditions on an annual basis. Annual compliance certification is required by WAC 173-401-630(5). 40 CFR 60.11(g) requires the permittee to consider credible evidence when submitting compliance certifications for NSPS affected units (EU-1, EU-2, & EU-3). Any deviations from permit conditions or certifications of intermittent compliance need to be accompanied by an explanation.

WAC 173-401 does not provide a deadline date for submission of the annual compliance certification, but a deadline date is necessary to make the requirement enforceable. The April 15th date was chosen because it is the date by which the annual emissions inventory report must be submitted in accordance with WAC 173-400-105.

R6. Emission Inventory Reports

The permittee is required to report an inventory of emissions from the source, and certify compliance with all permit terms and conditions on an annual basis. A complete emissions inventory includes quantifiable emissions from all EUs and IEUs. It is not expected that emissions from the IEUs identified in Section III will be quantifiable.

R7. Source Test and RATA Reports

Condition 17.5 of EFSEC/95-02 Amendment 2 requires submittal of the results of combustion turbine compliance tests as an element of the data that must be submitted along the timeline specified in Condition 16. Consistent with Condition 16, compliance source test reports for the combustion turbines must be submitted no later than 30 days after the end of the calendar quarter during which the testing was conducted. The PSD permit does not include a requirement to submit RATA test reports. WAC 173-401-630(1) requires that the Air Operating Permit include reporting requirements sufficient to assure compliance with the terms and conditions of the permit. Review of RATA reports is an important part of assuring compliance with the CEMS conditions; therefore submittal of RATA reports was required along the same timeline as source emission test reports.

Reports for RATAs conducted pursuant to 40 CFR 75 may be required at an earlier date if requested by EPA Region X or EFSEC.

In accordance with Condition 12 of EFSEC/2009-01, the results of all source emissions testing of the Auxiliary Boiler must be reported to EFSEC within 45 days of test completion.

VIII. EXPLANATION OF FUTURE REQUIREMENTS

No future requirements are anticipated.

IX. EXPLANATION OF OBSOLETE REQUIREMENTS

1. Obsolete Air Emission Permits/Orders

EFSEC/95-02 was issued on June 18, 1997 for construction and operation of the Chehalis Generation Facility. EFSEC/95-02 approved installation of two 230 MW combined cycle combustion turbines and a single auxiliary boiler. The turbines would primarily fire natural gas, but could fire fuel oil when natural gas was not available. SCR was not required.

EFSEC/95-02 Extension 1 was issued on November 16, 1998. EFSEC/95-02 Extension 1 approved an 18 month extension of the PSD approval to begin actual construction of the Chehalis Generation Facility.

EPA Administrative Order On Consent No. CAA-10-2001-0095 was issued March 22, 2001. The Consent Order required the facility to request a PSD permit revision requiring the installation of SCR to control NO_x emissions to 3.0 ppmvd @ 3% O₂ while firing natural gas and 14 ppmvd @ 3% O₂ when firing fuel oil. The Consent Order also allowed the facility to begin actual construction of the facility prior to receiving the revised PSD permit. The Consent Order terminated with issuance of PSD permit EFSEC/95-02 Amendment 1.

EFSEC/95-02 Amendment 1 was issued on April 17, 2001. EFSEC/95-02 Amendment 1 approved a revision of the NO_x emission limit to 3.0 ppmvd @ 3% O₂ while firing natural gas and 14 ppmvd @ 3% O₂ when firing fuel oil.

EFSEC/95-02 Amendment 2 was issued July 17, 2006. EFSEC/95-02 Amendment 2 modified opacity monitoring requirements when firing natural gas, modified the exempted startup time applicable to cold startups and removed references to the previously approved auxiliary boilers (the boilers were never constructed and approval to construct the boilers had expired).

Prevention of Significant Deterioration (PSD) review was conducted for initial installation of Combustion Turbines #1 and #2 resulting in issuance of EFSEC/95-02 on June 18, 1997. Nitrogen oxides, carbon monoxide, sulfur dioxide, particulate matter with an aerodynamic diameter less than 10 micrometers, volatile organic compounds, and sulfuric acid mist underwent PSD review in this permitting action. No permitting action since that time has triggered PSD review.

2. 40 CFR 60.7 "Notification and Record Keeping"

The combustion turbines are subject to 40 CFR 60.330 *et seq.* (Subpart GG) "Standards of Performance for Stationary Gas Turbines." Therefore, these units are also subject to the notification requirements of 40 CFR, Section 60.7. These requirements have been met as described below.

Combustion Turbine

Notification of construction: Submitted to EFSEC via letter dated October 25, 2001
 Notification of anticipated startup: Submitted to EFSEC via letter dated March 13, 2003
 Notification of actual startup: Submitted to EFSEC via letter dated June 17, 2003

The Auxiliary Boiler is subject to 40 CFR 60.40c et seq. (Subpart Dc) "Standards of Performance for Small Industrial-Commercial-Institutional Steam Generating Units." This unit was subject to the initial notification requirements of 40 CFR, Section 60.7. These notifications have been completed as described below:

Notification of construction: Submitted to EFSEC via letter dated March 5, 2009
Notification of anticipated startup: Submitted to EFSEC via letter dated November 8, 2010
Notification of actual startup: Submitted to EFSEC via letter dated January 7, 2011

3. 40 CFR 60.8 "Performance Tests"

The combustion turbines are subject to the NO_x standard described in 40 CFR 60.332. Therefore the unit is also subject to the performance testing requirements of 40 CFR 60.8. These requirements have been met as described below.

Notification of source test dates: Submitted to EFSEC on July 29, 2003
Initial source test: Performed on August 20-21, 2003 (CT1)
Performed on August 23-24, 2003 (CT2)
Source test report: Initial Report Dated November 25, 2003
Revised Report Dated April 22, 2004

4. 40 CFR 75.61 "Notifications"

The combustion turbine is subject to the requirements of 40 CFR 75.61 "Notifications." These requirements have been met as described below.

Notification of actual startup date: Submitted to EFSEC on June 17, 2003
Notification of initial CEMS certification: Submitted to EFSEC on July 29, 2003
Initial CEMS certification test: Completed on August 21, 2003 (CT1)
Completed on August 23, 2003 (CT2)

5. 40 CFR 75.62 "Monitoring Plan"

The combustion turbine is subject to the requirements of 40 CFR 75.62 "Monitoring Plan." The initial monitoring plan required by 40 CFR 75.62 was submitted to EFSEC and EPA on July 15, 2003.

6. 40 CFR 75.63 "Initial Certification or Recertification Application"

The combustion turbine is subject to the requirements of 40 CFR 75.63. The results of the initial CEM certification tests were submitted to EPA on December 23, 2003.

X. EXPLANATION OF APPENDICES

Appendix A contains the method by which visible emissions from the permittee's operations are to be evaluated when performing required monitoring. The federal requirements mandate the use of EPA Method 9. For EPA Method 9, the data reduction procedures detailed in EPA Method 9 must be used, not the procedures listed in Section 3 or Ecology Method 9A.

XI. FACILITY HISTORY

Permit/Regulatory Order Actions

The following table lists each Notice of Construction approval and Regulatory Order issued for this facility. Permits or Regulatory Orders in bold contain no active requirements. The requirements may have been superseded or may have been of limited duration.

<u>Number</u>	<u>Date Issued</u>	<u>Description</u>
EFSEC/95-02	6-18-97	Initial approval for construction and operation of the Chehalis Generation Facility. Approved installation of two 230 MW combined cycle combustion turbines and single auxiliary boiler.
EFSEC/95-02 Extension 1	11-16-98	Approved an 18 month extension of the PSD approval to begin actual construction.
EPA Administrative Order on Consent No. CAA-10-2001-0095	3-22-01	Allowed the facility to begin actual construction prior to receiving PSD permit. Required the facility to request a PSD permit revision requiring the installation of SCR to control NO _x to 3.0 ppmvd @ 3% O ₂ when firing natural gas, and 14 ppmvd @ 3% O ₂ when firing oil.
EFSEC/95-02 Amendment 1	4-17-01	Approved a revision of the NO _x limits to 3.0 ppmvd @ 3% O ₂ when firing natural gas, and 14 ppmvd @ 3% O ₂ when firing oil.
EFSEC/95-02 Amendment 2	7-17-06	Modified opacity monitoring requirements when firing natural gas, modified startup provisions for cold startups, removed references to auxiliary boilers (were not constructed, approval had expired).
EFSEC/2009-01	9-4-09	Approval of a natural gas startup boiler with a capacity of up to 30 MMBtu/hr.

Title V Permit Actions

Air Operating Permit **EFSEC/06-01-AOP**

- | | |
|--|--------------|
| 1. Renewal Permit Application Submitted: | May 12, 2004 |
| 2. Permit Application Deemed Complete: | May 25, 2004 |
| 3. Permit Application Sent to EPA: | May 25, 2004 |

- | | | |
|----|-------------------------|------------------|
| 4. | Draft Permit Issued: | April 10, 2006 |
| 5. | Proposed Permit Issued: | July 11, 2006 |
| 6. | Final Permit Issued: | October 10, 2006 |

Air Operating Permit EFSEC/06-01-AOP Rev. 1

- | | | |
|----|---------------------------------------|-------------------|
| 1. | Renewal Permit Application Submitted: | December 15, 2010 |
| 2. | Permit Application Deemed Complete: | March 3, 2011 |
| 3. | Permit Application Sent to EPA: | March 4, 2011 |
| 4. | Draft Permit Issued: | June 24, 2011 |
| 5. | Proposed Permit Issued: | August 19, 2011 |
| 6. | Final Permit Issued: | October 10, 2011 |

Air Operating Permit EFSEC/06-01-AOP Rev. 2

- | | | |
|----|---------------------------------------|-------------------|
| 1. | Renewal Permit Application Submitted: | October 6, 2015 |
| 2. | Permit Application Deemed Complete: | May 20, 2016 |
| 3. | Permit Application Sent to EPA: | July 29, 2016 |
| 4. | Draft Permit Issued: | August 25, 2016 |
| 5. | Proposed Permit Issued: | October 11, 2016 |
| 6. | Final Permit Issued: | December 29, 2016 |

Compliance History

The following permit deviations occurred during the last permit term (December 29, 2016 to present).

Hours of Exceedance					
Date	Unit	CO	NO _x	NH ₃	Notes
3-26/27-2019	Both				Failed NO _x RATA - Montrose informed plant they passed, later the report indicated differently. Discovered 7/3/2019 by PacifiCorp during report review. Closed out by EFSEC letter dated October 4, 2019.
10/27/2019	2		1		NO _x deviation - CT2 Sunday October 27, 2019. Control logic for ammonia flow needed improvement. Closed out by EFSEC letter dated December 10, 2019.
12/26/2020	1	6	6		Breaker indication mechanical failure, stuck at about 20 MW for extended duration until BPA islanded the plant and they could manually open the breaker. Closed out by EFSEC letter dated January 11, 2021.
12/27/2020	2		1		Failed ammonia control valve. Closed out by EFSEC letter dated January 11, 2021.
5/5/2021	2	1	1		Unplanned runback of CT2 to level below which emission controls operate during startup of CT1.

Appendix A: Plant Drawings

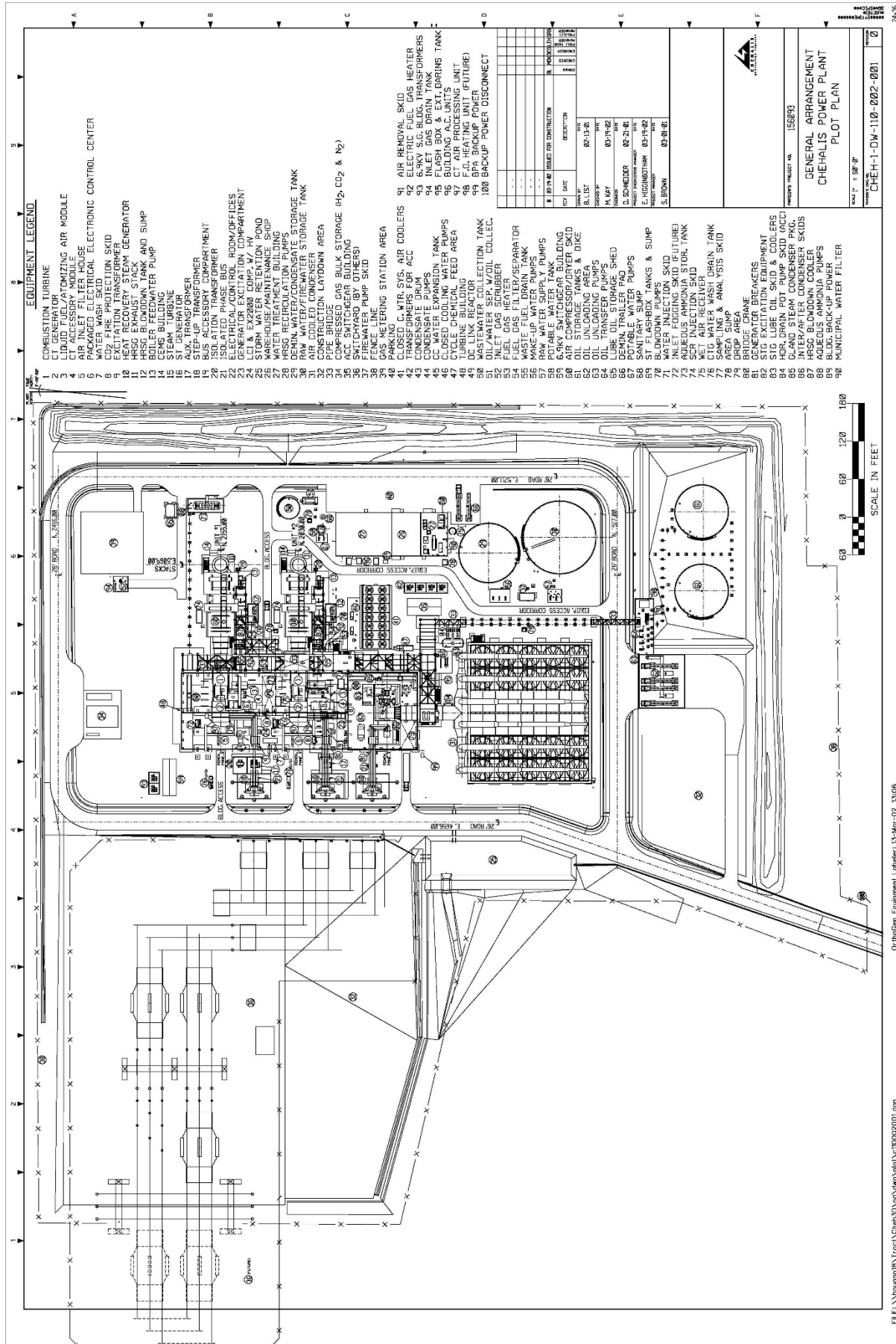

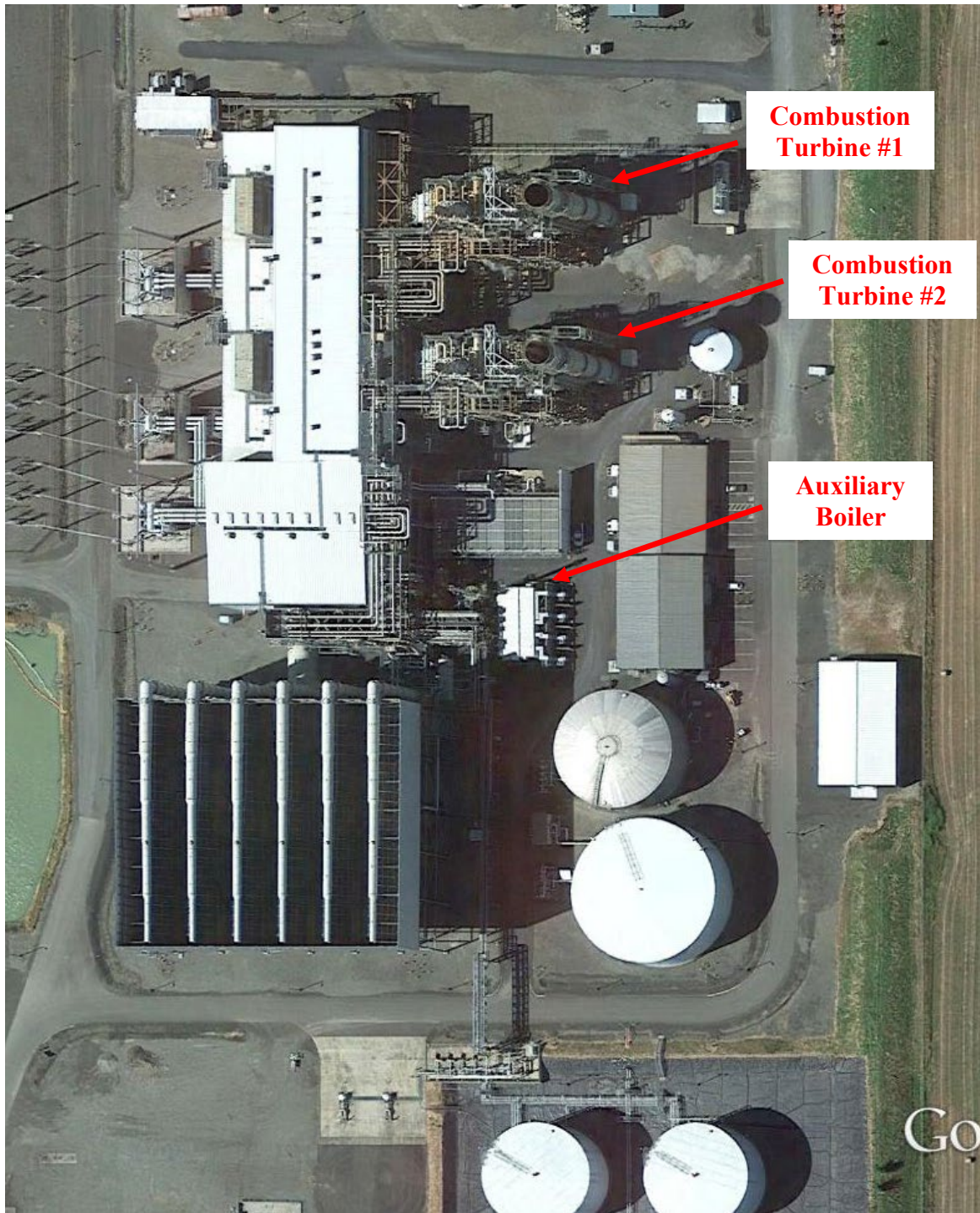

Google Earth Imagery – July 16, 2014

Chehalis Generating Facility - Process Flow Diagram

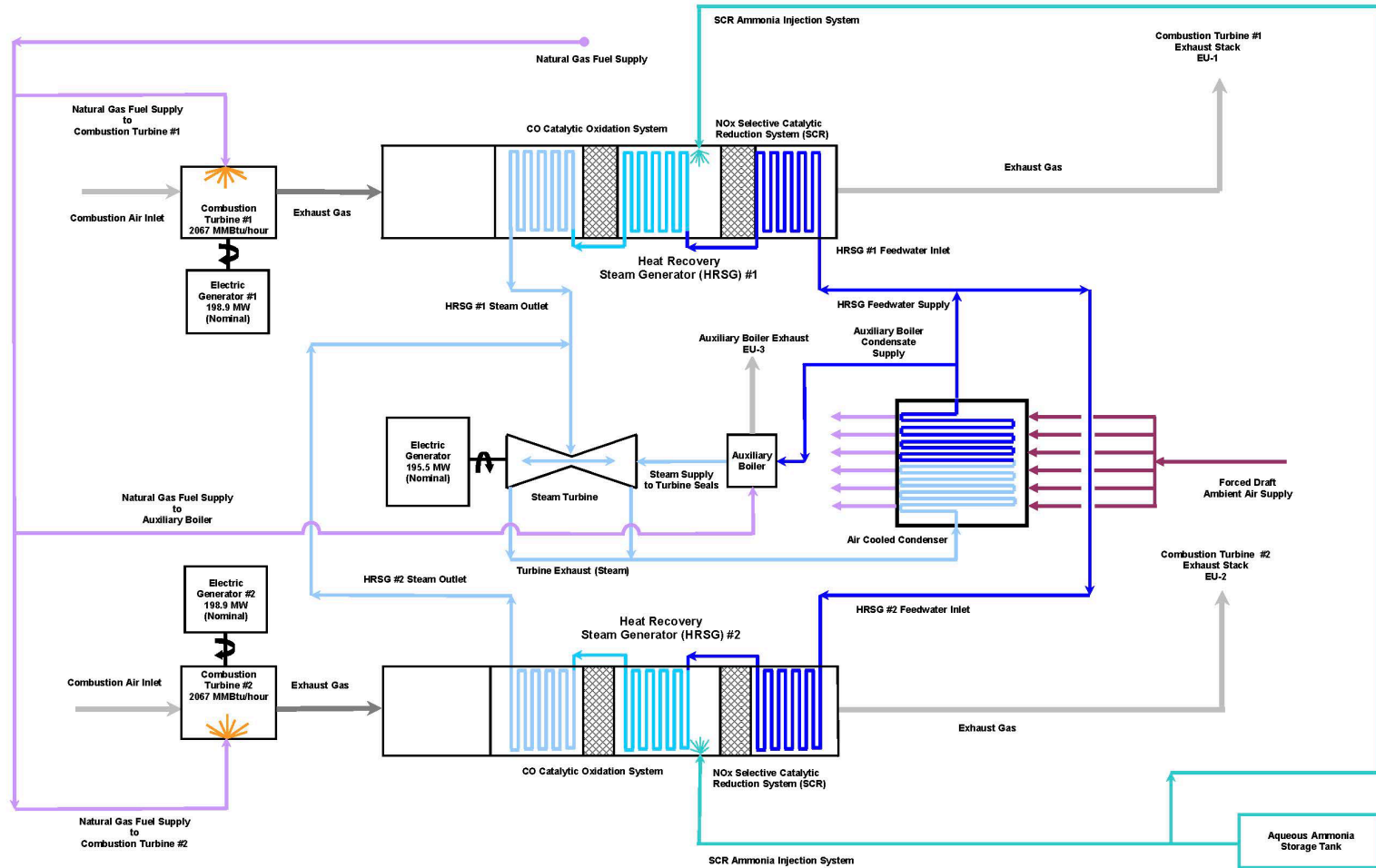

J. Doak
10/20/2010

Appendix B: Applicable Requirements Review

CFR 60 Subpart Dc – Standards of Performance for Small Industrial-Commercial-Institutional Steam Generating Units		
Requirement	Title V Permit Location	Comments
60.40c	—	"Applicability and Delegated Authority?" Informational. Subpart applies to boilers between 10 and 100 MMBtu/hr heat input. The Auxiliary Boiler has a heat input rating of 16.9 MMBtu/hr and is subject to this subpart.
60.41c	—	"Definitions." Informational.
60.42c	—	"Standards for sulfur dioxide (SO ₂)" None of the standards apply to a boiler that burns only natural gas.
60.43c	—	"Standards for particulate matter." None of the standards apply to a boiler that burns only natural gas.
60.44c	—	"Compliance and performance test methods and procedures for sulfur dioxide." This section is not applicable because there are no applicable standards for sulfur dioxide.
60.45c	—	"Compliance and performance test methods and procedures for particulate matter." This section is not applicable because there are no applicable standards for particulate matter or opacity.
60.46c	—	"Emission monitoring for sulfur dioxide." This section is not applicable because there are no applicable standards for sulfur dioxide.
60.47c	—	"Emission monitoring for particulate matter." This section is not applicable because there are no applicable standards for particulate matter or opacity.
60.48c	"Reporting and recordkeeping requirements."	
60.48c(a)	—	Initial Notification. Notice of construction submitted to EFSEC by letter dated 3/5/2009, notification of anticipated startup submitted to EFSEC via letter dated 11/8/2010, notification of actual startup submitted to EFSEC via letter dated 1/7/2011.
60.48c(b)	—	SO ₂ performance test reporting. Not applicable because the SO ₂ standard is not applicable.
60.48c(c)	—	Visual emissions - excess emissions reporting. Not applicable because the visual emissions standard is not applicable.
60.48c(d & e)	—	Reports required for facilities subject to the SO ₂ , fuel oil sulfur limits or percent reduction limits. None of these apply to this facility.
60.48c(f)	—	Required information for fuel supplier certification. No fuel supplier certification is required because the facility is not subject to a relevant emission standard.

CFR 60 Subpart Dc – Standards of Performance for Small Industrial-Commercial-Institutional Steam Generating Units		
Requirement	Title V Permit Location	Comments
60.48c(g)	M8	Fuel usage recordkeeping. In accordance with 60.48c(g)(2), facilities that burn only natural gas (as is the case here) may elect to record and maintain records of the amount of fuel combusted each calendar month.
60.48c(h)	—	Annual capacity factor calculation. Not applicable because there is no capacity factor limit.
60.48c(i)	—	Reporting period. Not applicable because there are no required reports.

CFR 60 Subpart GG – Standards of Performance for Stationary Gas Turbines		
Requirement	Title V Permit Location	Comments
60.330	—	"Applicability and designation of affected facility." Informational. Subpart applies the two combustion turbines at this facility.
60.331	—	"Definitions." Informational.
60.332	Req-13	"Standards for nitrogen oxides." The standard in 60.332(a)(1) applies. This standard is vastly less restrictive than the limits in EFSEC/95-02 Amendment 2, therefore only the EFSEC/95-02 Amendment 2 limits is presented. Turbines are rated for 175 MW at peak heat input of 2,067 MMBtu; therefore, "Y" in the equation is 12.46. Standard = $0.0075 * (14.4) / 12.46 = 0.0087\% \text{ NO}_x @ 15\% \text{ O}_2$. Equivalent to 87 ppmvd @ 15% O ₂ .
60.333	Req-11	"Standard for sulfur dioxide." The standard is either (a) 150 ppmvd @ 15% O ₂ , or a prohibition on burning fuel containing in excess of 0.8% sulfur. The later standard is listed in the permit because it is directly comparable to the fuel limitations in EFSEC/95-02 Amendment 2.
60.334(a, b, & d)	—	"Monitoring of operations." 60.334(a & b) both apply to turbines that use water or steam injection. The turbines at this facility do not use water or steam injection.
60.334(c & e)	—	Allows the use of CEMS as required in paragraph (b) for determining compliance with NO _x limit if the turbine does not use water or steam injection. This monitoring is optional. Note that the CEMS required at this facility meet the standards in paragraph (b).
60.334(f)	—	Continuous parameter monitoring for NO _x . This monitoring is optional. Establishes standards for NO _x parameter monitoring.

CFR 60 Subpart GG – Standards of Performance for Stationary Gas Turbines		
Requirement	Title V Permit Location	Comments
60.334(g)	—	Continuous monitoring of parameters. Not applicable because this facility is not required to monitoring any of the applicable parameters addressed by this section.
60.334(h)	M7	Fuel sulfur monitoring. The fuel monitoring of 40 CFR 75 satisfies the fuel sulfur monitoring requirements of this section. Note that the owner/operator could elect not to monitor gaseous fuel sulfur content to comply with this requirement if they made the demonstration that the fuel met the definition of "natural gas." The monitoring conducted to demonstrate compliance with 40 CFR 75 (including both daily sulfur monitoring on the pipeline by NW Pipeline and collection and analysis of on-site samples) has produced data sufficient to demonstrate that the gaseous fuel meets the definition of "natural gas."
60.334(i)	M7	Frequency of sulfur and nitrogen content monitoring. The fuel monitoring of 40 CFR 75 satisfies the fuel sulfur monitoring requirements of this section.
60.334(j)	—	Excess emission reporting for units where owner/operator elected to conduct optional monitoring under Subpart GG. This facility does not elect to conduct the optional monitoring referenced, and an exceedance of the sulfur standard (the only analogous monitoring conducted) is not possible, therefore this reporting is not applicable.
60.335	—	Test methods and procedures. All applicable testing has been completed.

EFSEC/95-02 – Amendment 2 (PSD NSR Permit for Combustion Turbines)		
Condition	Title V Permit Location	Comments
1.1	Req-12	Requirement to utilize natural gas for turbines except for testing and when natural gas is not available.
1.2	Req-12	Turbines may be fueled on diesel when natural gas is not available and during testing.
1.3	R3	Requirement to report diesel fuel use by turbines.
2.1	Req-13	NO _x emission limit.
2.2	Req-13	NO _x emission limit.
2.3	Req-13	NO _x emission limit.
2.4	—	Initial NO _x GG compliance determination. All required initial testing has been completed.
2.5	M6	NO _x emission monitoring requirements.
3.1	Req-14	CO emission limit.
3.2	Req-14	CO emission limit.

EFSEC/95-02 – Amendment 2 (PSD NSR Permit for Combustion Turbines)		
Condition	Title V Permit Location	Comments
3.3	—	Initial CO compliance requirements. All required initial testing has been completed.
3.4	M6	CO emission monitoring requirements.
4.1	Req-15	SO ₂ emission limit.
4.2	Req-15	SO ₂ emission limit.
4.3	—	Initial SO ₂ compliance requirements. All required initial testing has been completed.
4.4	—	Informational message that continuous monitoring for SO ₂ not required.
5.1	Req-16	VOC emission limit.
5.2	Req-16	VOC emission limit.
5.3	—	Initial VOC compliance determination method. All required initial testing has been completed.
6.1	Req-17	Filterable PM ₁₀ emission limit.
6.2	Req-17	Filterable PM ₁₀ emission limit.
6.3	—	Initial filterable PM ₁₀ compliance determination method. All required initial testing has been completed.
7.1	Req-18	H ₂ SO ₄ emission limit.
7.2	Req-18	H ₂ SO ₄ emission limit.
7.3	—	Initial H ₂ SO ₄ compliance determination method. All required initial testing has been completed.
8	Req-19	Visual emissions limit
8.1	M2	Compliance determination method for visual emissions limit.
8.2	M2	Alternative compliance determination method for visual emissions limit.
8.3	M2	Frequency of monitoring visual emissions when firing natural gas.
8.4	M2	Frequency of monitoring visual emissions when firing diesel.
8.5	—	States that a COMS may be used if meets requirements of Condition 14.4. The facility has not elected to use a COMS.
9.1	Req-20	Ammonia emission limit.
9.2	Req-20	Ammonia emission limit.
9.3	Req-20	Ammonia emission limit.
9.4	Req-20	Ammonia emission limit.
9.5	M6	Ammonia monitoring requirement.
10.1	Req-22	NO _x , CO, visual emissions limits in Conditions 2, 3, and 8 do not apply during startup and shutdown.
10.2	Req-21	Each turbine is limited to 200 startups per year.
10.3	Req-21	Each turbine is limited to 2 startups/shutdowns per 24-hour period.
10.4	Req-22	CO emission limit during startup and shutdown.
10.5	Req-22	NO _x emission limit during startup and shutdown.
10.6	Req-21	Definition of startup period.
10.7	Req-21	Shutdown time limitation, and definition of shutdown period.

EFSEC/95-02 – Amendment 2 (PSD NSR Permit for Combustion Turbines)		
Condition	Title V Permit Location	Comments
11.1, 11.2, 11.3	—	Initial performance testing requirements. All initial performance testing has been completed.
12	Req-23	Requirement for adequate sampling ports and platform.
13	Req-24	Requirement for adequate and safe access to test ports.
14.1	M6	CO CEMS requirements.
14.2	M6	NO _x /O ₂ CEMS requirements.
14.3	M6	NH ₃ CEMS requirements.
14.4	—	Optional COMS requirements. The facility has not elected to install a COMS.
14.5	M6	RATA frequency for NH ₃ and CO CEMS.
15.1	M5	Compliance testing frequency for PM ₁₀ , VOCs, H ₂ SO ₄ . Note that all references to PM ₁₀ in this permit refer to the filterable fraction only, therefore testing is limited to the filterable fraction.
15.2	M5	Criteria for reduced PM ₁₀ , VOC, H ₂ SO ₄ testing frequency.
16	R3	CEMS and process data reporting schedule.
17	R3	CEMS and process data report format and content.
18	R1	Reporting of deviations from emission limits.
19.1	Req-25	Development and availability of operating and maintenance manuals.
19.2	Req-25	Statement regarding agency use of operating and maintenance manuals.
20	—	18 month limitation on commencement of construction. This is no longer relevant.
21	—	Informational message regarding non-permit obligations.
22	—	Startup notification. This requirement has been completed.
23	G6	Agency access requirement.
24	—	Hourly and daily averaging based on clock hours and calendar days. Informational

EFSEC/2009-01 (Minor NSR Permit for Auxiliary Boiler)		
Condition	Title V Permit Location	Comments
1	Req-27	NO _x , CO, PM emission limits.
2	Req-28	Visual emissions limit.
3	Req-29	Boiler can only burn natural gas.
4	M8	Fuel consumption monitoring.
5	M8	Maintenance activities monitoring.
6	M1	Excess emissions recording.
7	M1	Recordkeeping details

EFSEC/2009-01 (Minor NSR Permit for Auxiliary Boiler)		
Condition	Title V Permit Location	Comments
8	VII	Records must be kept at least three years. This is less stringent than the requirement from WAC 173-401-615(2)(c) in the header of Section VII, therefore only the more stringent five year recordkeeping schedule is listed.
9	Appendix B	Source testing requirement and frequency.
10	Appendix C	Performance monitoring requirement and frequency.
11	R1	Excess emissions reporting. The provision noting that reports must be submitted within 48 hours if the permittee wishes to claim the event as unavoidable is informational in reproduced in
12	R7	Source test reporting deadline.
13	R1	Deviation reporting.
14	R6	Emissions inventory related reporting.